

### MODELS 171 - 351

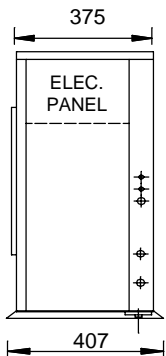

Pipe & Electrical Connections This Side

### MODELS 371 - 501

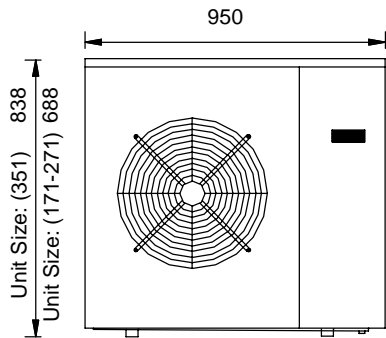
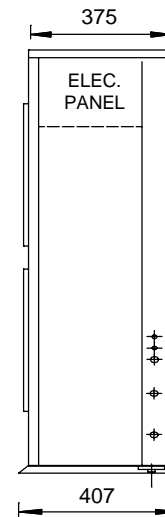
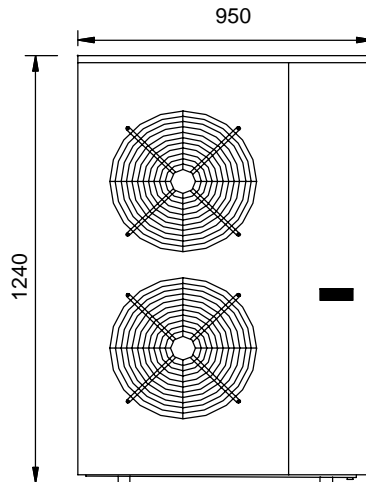

Pipe & Electrical Connections This Side

### MODELS 701-721

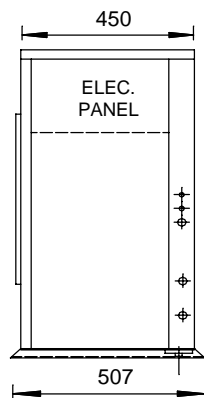
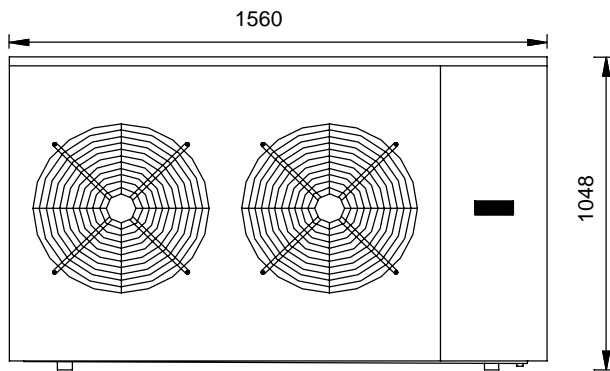

Pipe & Electrical Connections This Side

Dimensions (MM)

AXCZ/BZ	WEIGHT (KG)
171	66
201	68
221	70
251	73
271	73
351	83
371	102
401	108
451	110
501	120
701	180
721	196

## SECTION 2A.

Split Systems - Condenser/Outdoor Units (Cool Only & Heat Pump)  
Models AXCZ/BZ 171 - 721