

MODELS 171 - 351

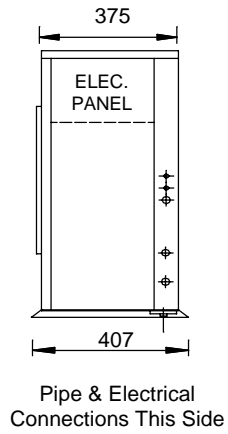

MODELS 371 - 501

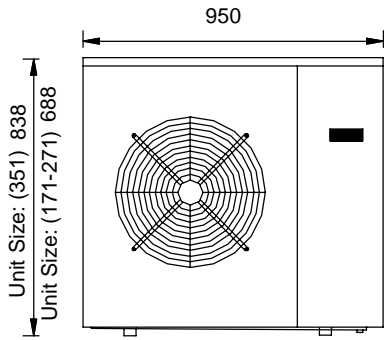
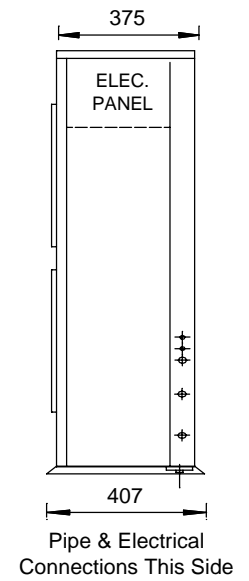
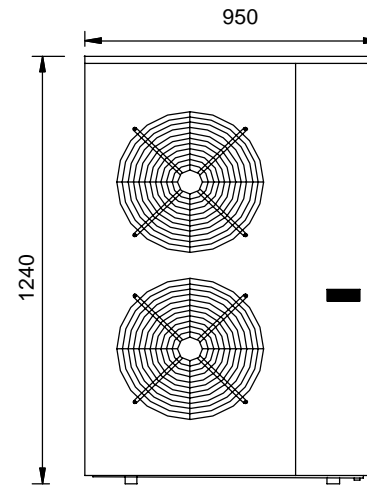

MODELS 701-721

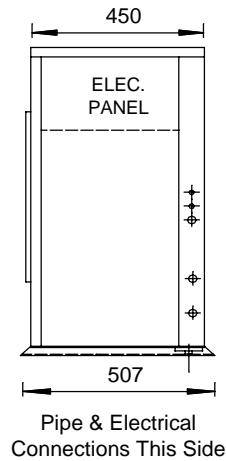
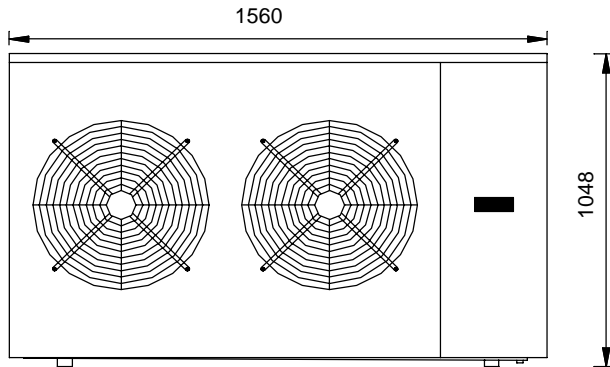

Dimensions (MM)

AXCZ	WEIGHT (KG)
171	66
201	68
221	70
251	73
271	73
351	83
371	102
401	108
451	110
501	120
701	180
721	196

SECTION 1.

Air Cooled Condensing Units - Axial Fan - Models (AXCZ 171 - 721)

DRG 1/1
MAY 2007